

70kW 60Hz Oil and Gas Generator Set

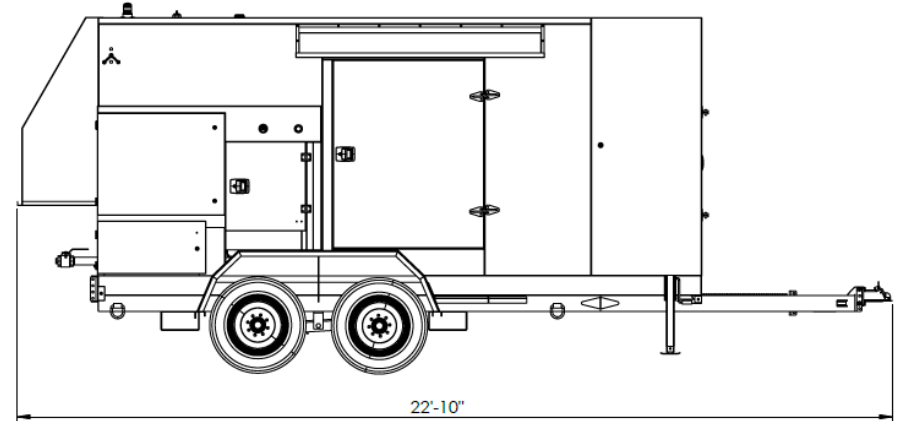
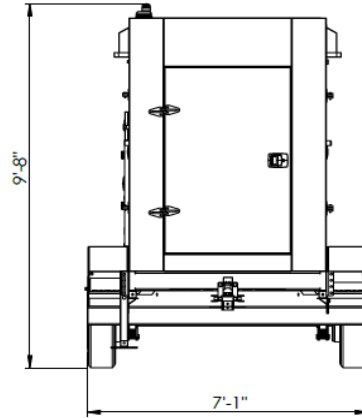

For more information regarding equipment specifications, please reach out to a Mesa sales rep.

Genset Information	
Voltage	480 V
Frequency	60 Hz
NG PRP Rating	70 kW 87 kVA
LP PRP Rating	70 kW 87 kVA
Wet Weight	9,689 lbs

Engine Information	
Model	PSI 8.1L
Nameplate Rating	88 kW 118 hp
Speed	1,800 rpm
Displacement	8.1 L 492 in ³
Cylinder Arrangement	6 Cylinders Inline
Aspiration Mode	Natural

Fuel Consumption*		
Load %	NG Rating	LP Rating
100%	896,265 Btu/hr	862,409 Btu/hr
75%	730,158 Btu/hr	698,160 Btu/hr
50%	569,069 Btu/hr	545,190 Btu/hr
25%	412,999 Btu/hr	403,500 Btu/hr

* NG: HHV=1,041 Btu/scf (39 MJ/m³)
 LP: HHV=2,538 Btu/scf (95 MJ/m³)

Control System	
Controller Type	DSE 8610 MKII
Synchronizing & Load Sharing	Yes
Telemetry & Remote Monitoring	Yes

Alternator	
Manufacturer	Stamford
Model	UCI274E Wdg. 311
Rated Power Factor	0.8 PF
Rating	143 kW 179 kVA
Excitation Type	PMG
Insulation Class	Class H
Temp. Rise / Ambient	125 / 40°C
Enclosure	IP23

Emission Control	
AFR Controller	Yes
NSCR Catalyst	Yes