

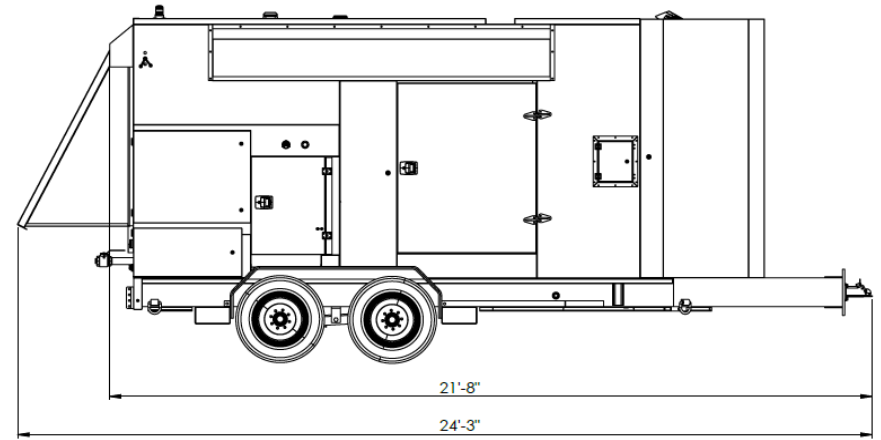

350kW 60Hz Commercial & Industrial Generator Set

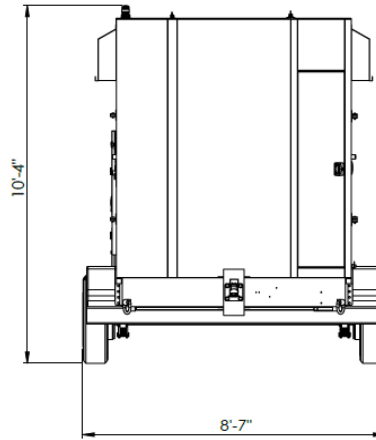

For more information regarding equipment specifications, please reach out to a Mesa sales rep.

Wiring Configurations			
Rated Voltage	480/277	240/139	208/120
Winding Configuration	Hi-Wye	Lo-Wye	Lo-Wye
Phase	3	3	3
Prime Power	350 kW 438 kVA	350 kW 438 kVA	346 kW 433 kVA
Rated Amps	526	1,052	1,200

Fuel Consumption*		
Load %	NG Rating	LP Rating
100%	4,174,532 Btu/hr	3,826,061 Btu/hr
75%	3,273,382 Btu/hr	2,928,679 Btu/hr
50%	2,398,244 Btu/hr	2,143,244 Btu/hr
25%	1,549,117 Btu/hr	1,469,754 Btu/hr

* NG: HHV=1,041 Btu/scf (39 MJ/m³)

LP: HHV=2,538 Btu/scf (95 MJ/m³)

Genset Information	
Voltage	480 V
Frequency	60 HZ
NG PRP Rating	350 kW 438 kVA
LP PRP Rating	310 kW 388 kVA
Wet Weight	16,989 lbs

Engine Information	
Model	PSI 21.9L
Nameplate Rating	434 kW 581 hp
Speed	1,800 rpm
Displacement	21.9 L 1,336 in ³
Cylinder Arrangement	12 Cylinders V-type
Aspiration Mode	Turbocharged

Alternator	
Manufacturer	Stamford
Model	S4L1D-G4 Wdg. 311
Rated Power Factor	0.8 PF
Rating	450 kW 563 kVA
Excitation Type	PMG
Insulation Class	Class H
Temp. Rise / Ambient	125 / 40°C
Enclosure	IP23

Control System	
Controller Type	DSE 8610 MKII
Synchronizing & Load Sharing	Yes
Telemetry & Remote Monitoring	Yes

Emission Control	
AFR Controller	Yes
NSCR Catalyst	Yes