

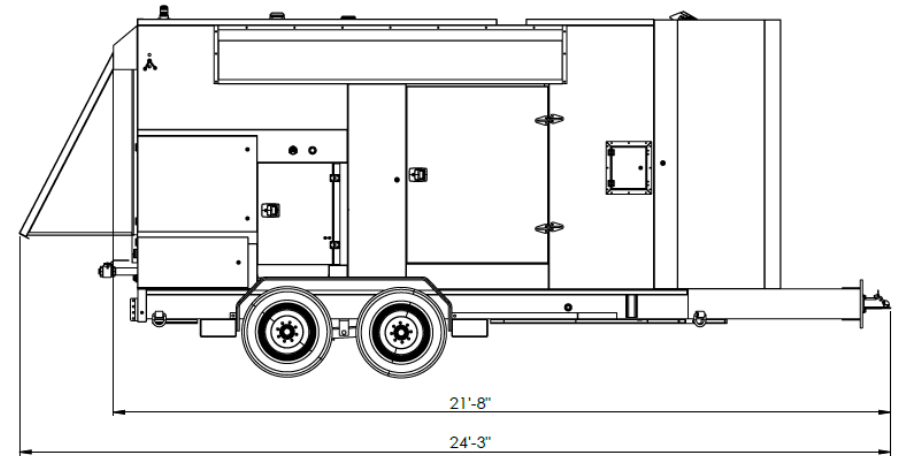

# 250kW 60Hz Oil and Gas Generator Set

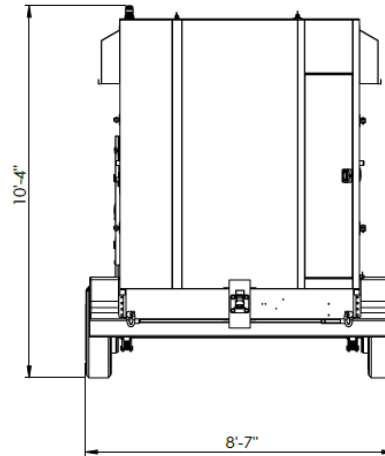

For more information regarding equipment specifications, please reach out to a Mesa sales rep.

Genset Information	
Voltage	480 V
Frequency	60 Hz
NG PRP Rating	250 kW   312 kVA
LP PRP Rating	225 kW   281 kVA
Wet Weight	15,289 lbs

Engine Information	
Model	PSI 14.6L
Nameplate Rating	290 kW   389 hp
Speed	1,800 rpm
Displacement	14.6 L   891 in <sup>3</sup>
Cylinder Arrangement	8 Cylinders V-type
Aspiration Mode	Turbocharged

Fuel Consumption*		
Load %	NG Rating	LP Rating
100%	2,944,253 Btu/hr	2,843,972 Btu/hr
75%	2,306,689 Btu/hr	2,178,964 Btu/hr
50%	1,689,974 Btu/hr	1,580,002 Btu/hr
25%	1,094,108 Btu/hr	1,047,087 Btu/hr

\* NG: HHV=1,041 Btu/scf (39 MJ/m<sup>3</sup>)  
LP: HHV=2,538 Btu/scf (95 MJ/m<sup>3</sup>)

Control System	
Controller Type	DSE 8610 MKII
Synchronizing & Load Sharing	Yes
Telemetry & Remote Monitoring	Yes

Alternator	
Manufacturer	Stamford
Model	S4L1D-D41 Wdg. 311
Rated Power Factor	0.8 PF
Rating	312 kW   390 kVA
Excitation Type	PMG
Insulation Class	Class H
Temp. Rise / Ambient	125 / 40°C
Enclosure	IP23

Emission Control	
AFR Controller	Yes
NSCR Catalyst	Yes