

# 125kW 60Hz Oil and Gas Generator Set

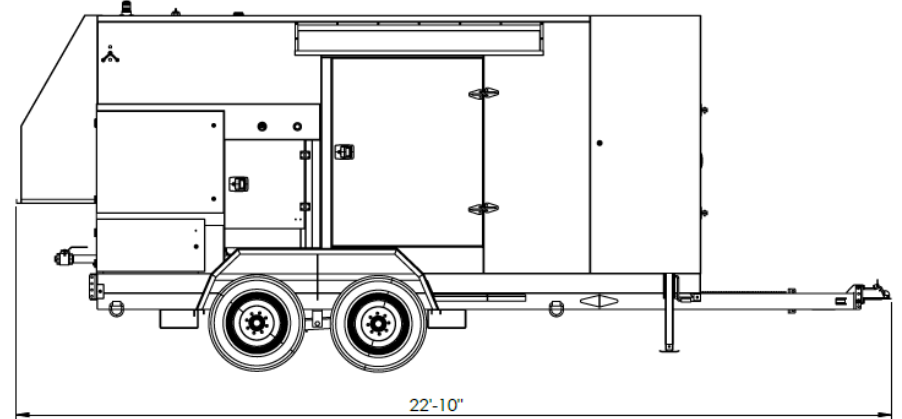
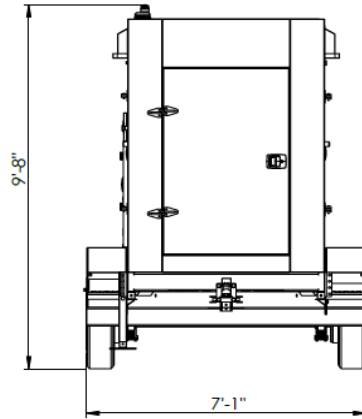

For more information regarding equipment specifications, please reach out to a Mesa sales rep.

Genset Information	
Voltage	480 V
Frequency	60 Hz
NG PRP Rating	125 kW   156 kVA
LP PRP Rating	105 kW   131 kVA
Wet Weight	10,029 lbs

Engine Information	
Model	PSI 8.1L
Nameplate Rating	150 kW   201 hp
Speed	1,800 rpm
Displacement	8.1 L   492 in <sup>3</sup>
Cylinder Arrangement	6 Cylinders Inline
Aspiration Mode	Turbocharged

Fuel Consumption*		
Load %	NG Rating	LP Rating
100%	1,509,862 Btu/hr	1,314,246 Btu/hr
75%	1,191,291 Btu/hr	1,043,871 Btu/hr
50%	884,639 Btu/hr	771,043 Btu/hr
25%	589,905 Btu/hr	495,763 Btu/hr

\* NG: HHV=1,041 Btu/scf (39 MJ/m<sup>3</sup>)  
LP: HHV=2,538 Btu/scf (95 MJ/m<sup>3</sup>)

Control System	
Controller Type	DSE 8610 MKII
Synchronizing & Load Sharing	Yes
Telemetry & Remote Monitoring	Yes

Alternator	
Manufacturer	Stamford
Model	UCI274G Wdg. 311
Rated Power Factor	0.8 PF
Rating	185 kW   231 kVA
Excitation Type	PMG
Insulation Class	Class H
Temp. Rise / Ambient	125 / 40°C
Enclosure	IP23

Emission Control	
AFR Controller	Yes
NSCR Catalyzt	Yes